

separlab

LIQUID CHROMATOGRPHY PUMP

SEPARTRIX PP 03 SAG



INSTRUCTION MANUAL

1. Use and Function of the Product

High-pressure pump PP03 SAG is designed for pumping corrosive liquids, against which is resistant stainless steel AISI 316, polytetrafluoroethylene (PTFE), ultra high molecular weight polyethylene (UHMWPE), polyetheretherketon (PEEK) polycrystalline corundum ceramics and crystallic carbon. Using three parallel cylinders for pumping with overlapping of displacement periods in 120° (without any delay and with maximum stroke) leads to a diminishing of pressure pulses in the hydraulic circuits and in most cases the pump can be considered as pulse less. It is therefore extremely suitable for an use in preparative high performance liquid chromatography.

Pump PP03 SAG is equipped with three gradient solenoid valves (situated on a single steel holder) on the inlet and in the pump case is integrated gradient programmer (it uses pump display and a second installed keyboard) and power supply for valves. The low pressure gradient of three components can be programmed in ten linear steps. This not only allows the use of pump in the gradient chromatography, but also convenient and reproducible dosing of the sample using C valve for when binary gradient is produced through valves A and B.

2. Product Description

Pump PP03 SAG is a piston pump equipped with one pump head which integrates three pumping cylinders with pistons, their seals, check valves and inlet and outlet fittings. The pistons are driven by three cam systems (Fig. 1). All their moving parts are stored in the ball bearings. Cam connecting rods are fitted at the end by small ball bearings that move in grooves formed by two steel combs. Pistons are connected to cams through especially shaped steel holders which are fixed to front surfaces of connecting rods. Movement of the shaft is provided with strong stepping motor through two teeth wheels and a teeth belt. Motor is located on a special table and is connected to the pump case by silent blocks in order to absorb motor vibrations. The motor speed is controlled by special power supply.

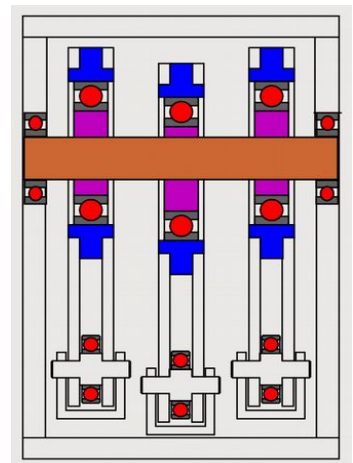

Fig. 1: Cam mechanics

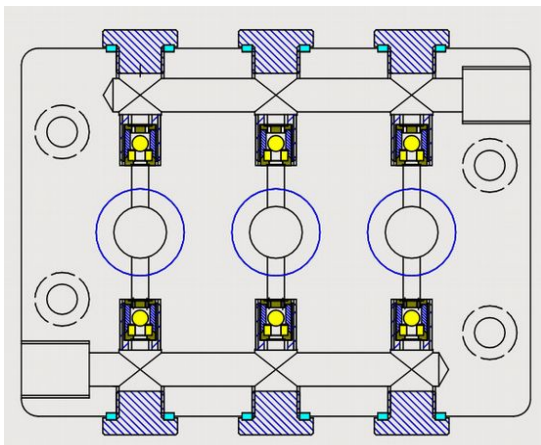

Fig. 2: Pumping head cross section

Pumping head (Fig. 2) is made of stainless steel with precision drilling holes. The pistons move in a cylindrical recess. The first part of each recess is adapted to the diameter of the piston (there is a PEEK made subcylinder inside steel one) and is used as pumping cylinder. Second part with substantially larger diameter is designed for a plastic sealing rings and compression spring made of stainless steel. The third part is provided with a thread and a screw with hole for the piston is inserted into, serving to guide the piston and to generate a power required to press seal rings. Between the through-bolt and the spring is placed secondary seal (Fig. 3). With this seal can be through-holes from the top of the head springs area washed to remove the liquid and keep unwanted

products out of the piston (buffer additives such as buffer crystals).

Main three seal rings are conical, made of special abrasion resistant ultra high-molecular weight chemically resistant polyethylene. Seals are pushed to the edge of the cone shaped front part of a cylindrical sealing groove.

Pistons (Fig. 4) are made of cut and polished stainless steel cylinders of outside diameter 10,0 mm. They are equipped on the cam end by a rotational groove which fit to U holes in piston holders. Piston are coated by polycrystalline carbon.

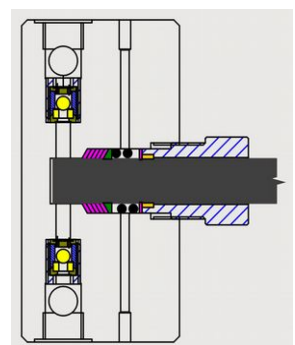

Fig. 3: Pump cylinder with piston

Inlet (Fig.5) and outlet (Fig.6) valves, are made as cartridges, whole exchanged. The outer portion of steel housings are equipped with M12 thread. Inside housings are pressed PEEK and PCTFE made parts as well as ceramic seats and balls.



Fig. 4: Piston unit

Valve cartridges are screwed from above and from below the pump head after removing

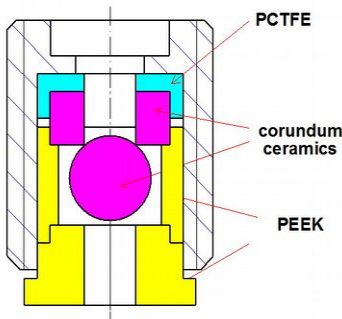

Fig. 5: Suction check valve

the plug with hexagonal heads (Fig 7). To allow screwing, cartridges are provided with hexagonal recess for key type HEX.

On both sides of pumping head are connected standard Swagelok type fittings for connecting of 1/4" (6,3 mm) O.D. tubing. Output tubing leads to the bypass valve block which is combined with pressure measurement gauge (Fig. 8). Cylindrical block has an input from the head in the upper part, on left side is a bypass output (1/8" (3,3 mm) O.D. Swagelok fitting) and on the right side is a 1/8" O.D. output fitting.

Pumping head protrudes from the front panel of the pump and is easily removable (four screws). From the back of the head are available through bolts Fig. 7) to adjust the pressure sealing spring forces. When removing the head is firstly necessary to release through bolts and to deassemble connecting tube to the bypass block. Then is to start the pump movement for small flow rate (cca 30 ml/min.) and use a middle force to move the head out of the case. After removing the piston head the pump has to be stopped immediately. To remove own pistons, the front panel of the pump and front panel of the cam mechanics must be deassembled.

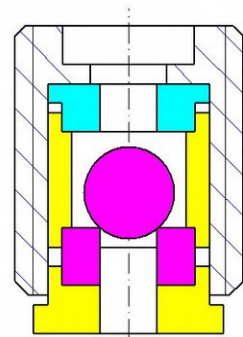

Fig. 6: Displacement check valve



Fig. 7: Hexagonal caps and valves inside head, back side tightening screws

The pump housing is made of stainless steel. It consists of front (angled) and the rear panel and two U shaped profiles. After removing the upper U-profile (the side bolts and bolts of an upper panels have to be released) are accessible all parts placed inside the case. Mechanics pump, motor and transformer are located on the rugged construction of 5 mm thick stainless steel sheet.

On the front panel is mounted electronic display board. Frequency generator for stepping motor is located on the cam mechanics box. Rear panel (Fig. 9) contain the power supply cable going through. There is a power switch with fuse too as well as external control connector and three connectors for connecting valves of gradient.

On the front panel is mounted electronic display board. Frequency generator for stepping motor is located on the cam mechanics box. Rear panel (Fig. 9) contain the power supply cable going through. There is a power switch with fuse too as well as external control connector and three connectors for connecting valves of gradient.

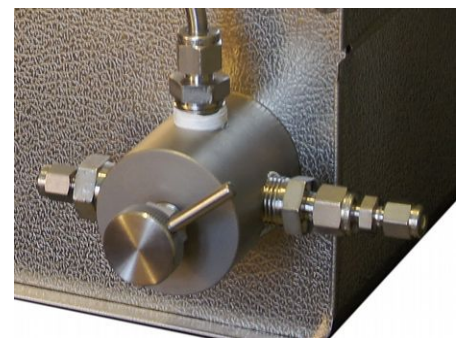

Fig. 8: Bypass block

Pump PP03S BG is delivered with gradient mixer. Gradient programmer is integrated in the pump using second installed keyboard (a right one, see Fig. 10). Gradient valves are connected to connectors on the back pump panel and situated on single small stainless steel table (Fig. 11). They are made of 316 AISI stainless steel with PTFE sealing and connected



Fig. 9: Pump back panel



Fig. 10: Pump and gradient keyboards

together

due an triangle fitting. Output from gradient valves in in the bottom part of the fitting under the table. On valves input are connected Swagelok type fittings allow to connected FPA or PTFE tubing O.D. 1/4". On the output is a standard Swagelok fitting for 1/4" (6,3 mm) stainless steel tubing as well. Due this fitting and short tube gradient valves are connected to the pumping head having the input for 1/4" tubing too.

It is recommended to place mobile phase reservoirs to the most upper place and both gradient valves and the pump to the low place. Even all tubing in the pump system are designed to work well with maximal flow rate 800 ml/min., such arrangement avoid problems with cavitation in pump cylinders.

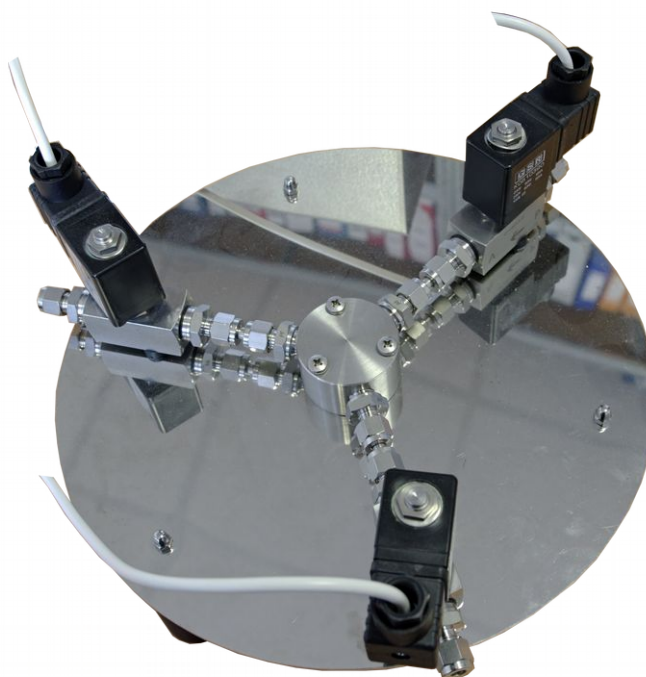

Fig. 11: Gradient valves

3. Basic data of the pump

Number of pistons:	3
Piston diameter:	10 mm
Piston stroke:	10 mm
Cycle frequency:	20 rpm - 330 rpm
Flow rate:	0,5 – 400,0 ml/min.
Pressure limit:	3 - 200 Bar
Pressure hysteresis:	1-15 Bar
Gradient:	3 phases
Number of linear gradient steps:	10
Time of gradient step:	0,1-180 min.
Pump input:	800 W
Dimensions (depth x width x hight):	610 mm x 385 mm x 280 mm
Weight:	40 kg

4. Pump control

The pump can be controlled independently from the keyboard on the front panel or externally via RS232 serial port. When external control is active, the keypad is locked and it is impossible to control the keyboard just to view the specified parameters. Always works but the STOP button.

Left keyboard is used for pump control, the right to control the gradient. For the transition from pump control to the control of the gradient is necessary to press ENTER on the keyboard and the right to go to the pump control is necessary to press ENTER on keyboard left.

Description of Keyboard 1 drawing

F1:	used to move items between displays down
F2:	used to move items between displays up
The key "arrow down":	used for deleting the value
Key "arrow up":	used for adding value
ENTER key:	used to confirm the value
Key START / STOP:	is used for starting and stopping the pump
This key is functional on any item at any time so we can start and stop the gradient, is the key functional even if the system is controlled from an external source and the keyboard is off.	



The order of display items for controlling the pump:

Flow

Pressure

Flow Settings

Pressure Settings

Hysteresis Settings

Password Settings (the following items are accessible only after entering a password)

Settings Corection flow

Zero pressure settings

Max pressure settings

Max pressure settings

Description of Keypad 2 – gradient

F1:	used to move items between displays down
F2:	used to move items between displays up
The key "arrow down":	used for deleting the setpoint
Key "arrow up":	used for adding setpoint
ENTER key:	used to confirm the setpoint
Key START / STOP:	is used for starting and stopping the gradient
This key is functional on any item at any time so we can start and stop the	



gradient, is the key functional even if the system is controlled from an external source and the keyboard is off.

The order of display items for controlling the gradient:

Status Display

A Gradient Settings (segment 0)

Settings of Gradient B (segment 0)

Time Settings (segment 0)

A Gradient Settings (Segment 1)

... ..

A Gradient Settings (segment 10)

Settings of Gradient B (segment 10)

Example of operation – pump

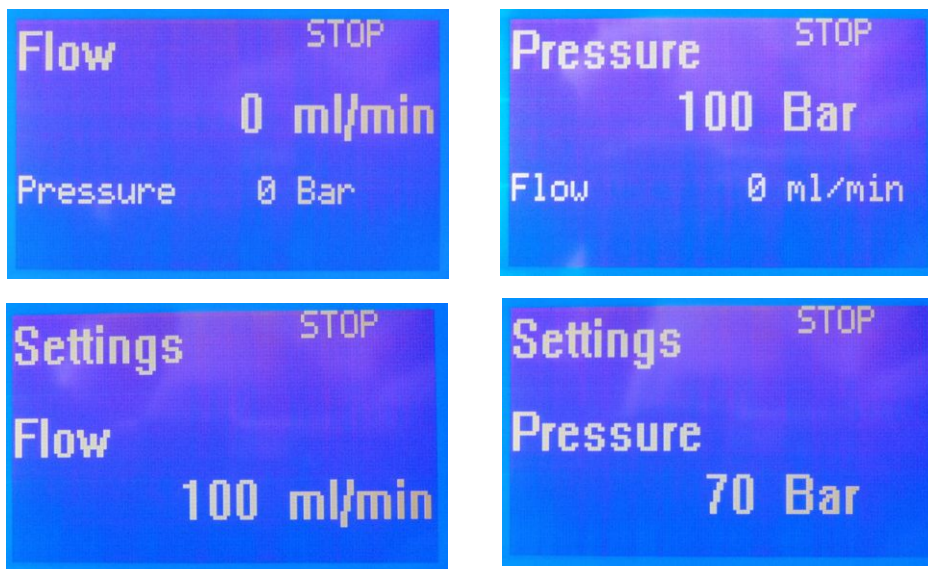

After switching on the pump is set to display the first item. In the upper right corner shows the status of the pump (at this moment, STOP). The display shows the current flow and the current pressure. After pressing the F1 key to get to the second operating item display, where it is displayed as the current primary pressure and secondary current flow.

Pressing the F1 key gradually check set flow rate, pressure, and hysteresis and end up in the Password entry, where the other items we get to the password.



After checking the set of values is possible by pressing F2 to return to the default item and we can start the pump by pressing the START / STOP. After pressing the change in the upper right corner is visible (to RUN) and the pump starts to pump. If not, it is possible that the pump is blocked by one of the following reasons.

- a) pressure exceeded the set limit (in the bottom row shows the actual pressure)
- b) autonomic control is disabled with the command on the serial line
- c) drive motor is not ready or is in an error state, then RUN flashes for a while and just starts STOP.



Then is possible pressing the START / STOP again to stop the pump. The pump motor starts stops rotation stepwise during approx. 4 s.

Pressure limit control function stops and starts the pump depending on the current pressure which was set. To avoid fast on and off switching, an interval in which pump stops and starts again is to be set. This interval is called hysteresis and can be set between 1 and 15 bar. It is recommended to set hysteresis between 5 and 10 bar. Pump stops when the real pressure excess set pressure limit + hysteresis and starts again when pressure is going down set pressure value - hysteresis. T

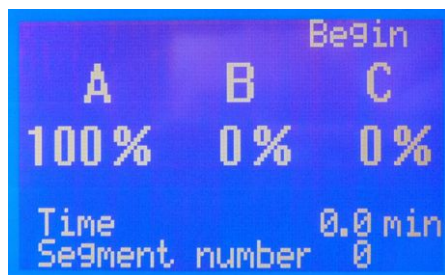

Example of gradient control

To switch to control the gradient on the right keyboard, press ENTER. And by pressing F1 or F2, one can check the settings gradient. Gradually, item "Settings Gradient A", "Settings Gradient B" and "Time Settings" is displayed for the gradient segments up to segment 9, which is the last one (there is no longer possible to specify a time). When entering the gradient A value, system gradually calculates



the value of B and C so that anytime is true $A + B + C = 100$. Taking the first gradient step, C is assumed to be $C = 0$, thus regulating the gradient of B. After pressing ENTER the instrument shall be recorded in all three gradient values A, B and C.

When enter the value of B, C is can reached like $100 - A - B$ (correct value is displayed after pressing ENTER). When composition is defined, time of each linear segment is to be set. It is possible to stop gradient in any step, The last step of gradient programme is to be set to zero at such case.

Example of the gradient

Gradient A = 100 % (segment 0)
Gradient B = 0%
Time = 10.0 min
Gradient A = 50% (Segment 1)
Gradient B = 50%
Time = 5.0 min
Gradient A = 50% (Segment 2)
Gradient B = 0%
Time = 0 min

The gradient segment 0 is displayed, pump is running, the composition 100 % A is delivered, in the upper right corner of the keyboard shows "BEGIN". After pressing the START / STOP button on the right keyboard starts the gradient and in the upper right corner of the display will change "BEGIN" to "RUN". On the status display item then one can watch the current gradient, a given time and the running segment. In 10 min. composition is decreased linearly to 50 % A and B increases to 50 %, C = %. After further 5 min., composition is keeping to 50 % A, decreasing B to 0 % and C increases to 50 %. Then gradient run stops and End is displayed in the right corner of the display. Pump is still running, keeping last composition, i.e. 50 % A and 50 % C. Next (third) pressing the START / STOP returns composition to the default gradient composition (gradient segment 0).

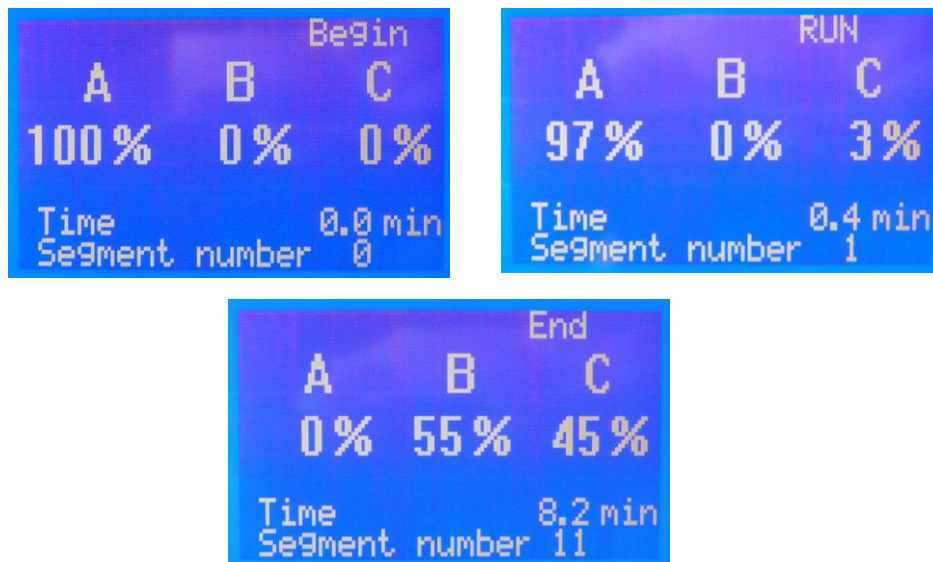

Another possibility how to stop gradient is to press the START / STOP button anytime during the run. Pump is running, delivering composition which was on the screen at the moment of STOP action. Next (third) pressing the START / STOP returns composition to the default gradient composition (gradient segment 0).

Graphic interpretation of described gradient run 1 is on the Fig. 12.

NOTE: If programmed all steps the gradient will reach the last fictitious segment 11 and stops.

NOTE: Gradient runs in 6-second loop from the pump turn on by power switch. For a smooth and homogeneous process gradient can only be started at zero time in 6-second loop. Therefore, the gradient does not start immediately after pressing START/STOP, but with a delay of up to 6s just as the pump passes through zero the loop.

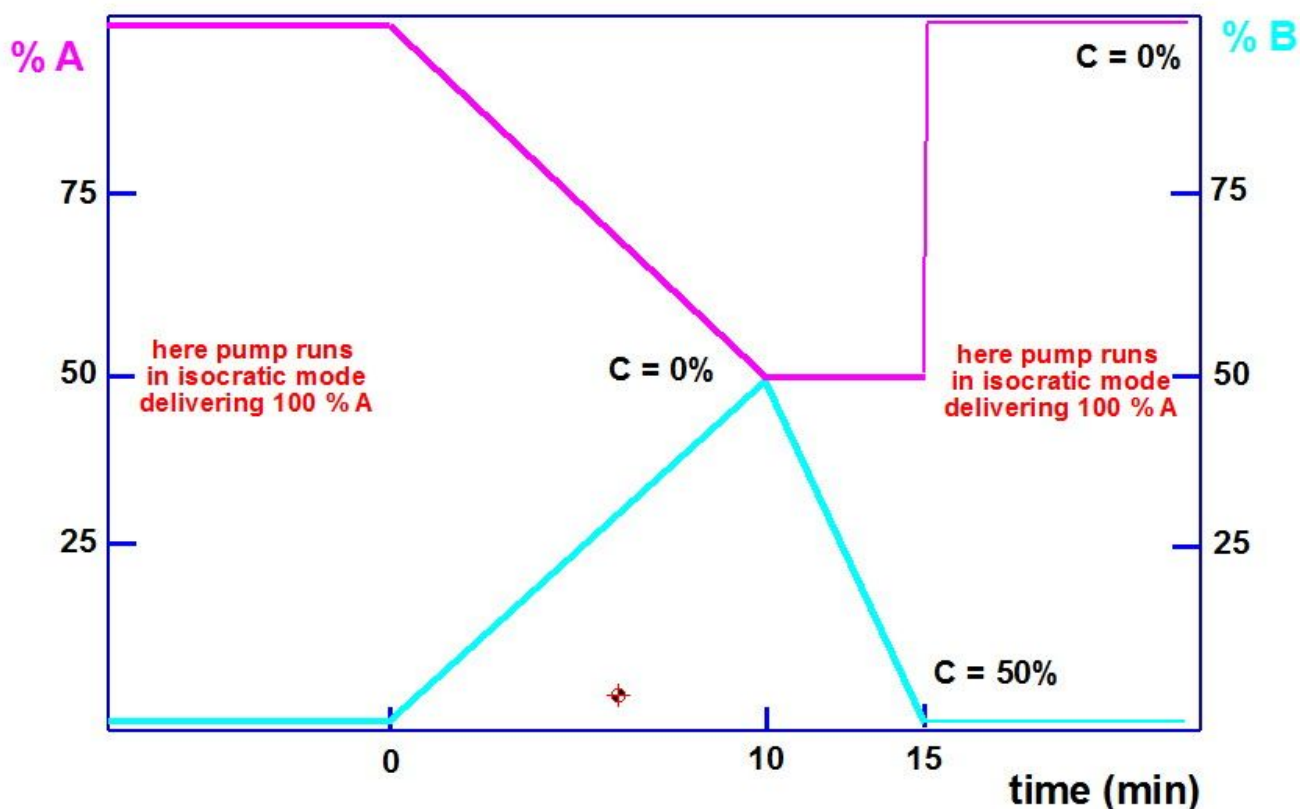

Fig. 12

Example of sample injection

It is advantageous to use gradient system not only to change mobile phase composition, but to inject sample as well. In such case two phases gradient can be still used, but one liquid input is reserved for sample injection.

Let suppose, that for injection is reserved valve C and that we would like to separate sample with gradient starting with 80 % A and 20 % B, keeping the composition 5 min after the injection and then change the composition in 30 min. to 20 % A and 80 %B. Suppose that the sample will be injected 3 min. from valve C on the beginning. Gradient programming is done as follows:

Gradient A = 80 %	(segment 0)
Gradient B = 20%	
Time = 0.1 min	
Gradient A = 0%	(Segment 1)
Gradient B = 0%	
Time = 3.0 min	
Gradient A = 0%	(Segment 2)
Gradient B = 0%	
Time = 0,1 min	
Gradient A = 80%	(Segment 3)
Gradient B = 20%	
Time = 30,0 min	
Gradient A = 20%	(Segment 4)Gradient B = 80%
Time = 0 min	

Graphic interpretation of described gradient run 1 is on the Fig. 13.

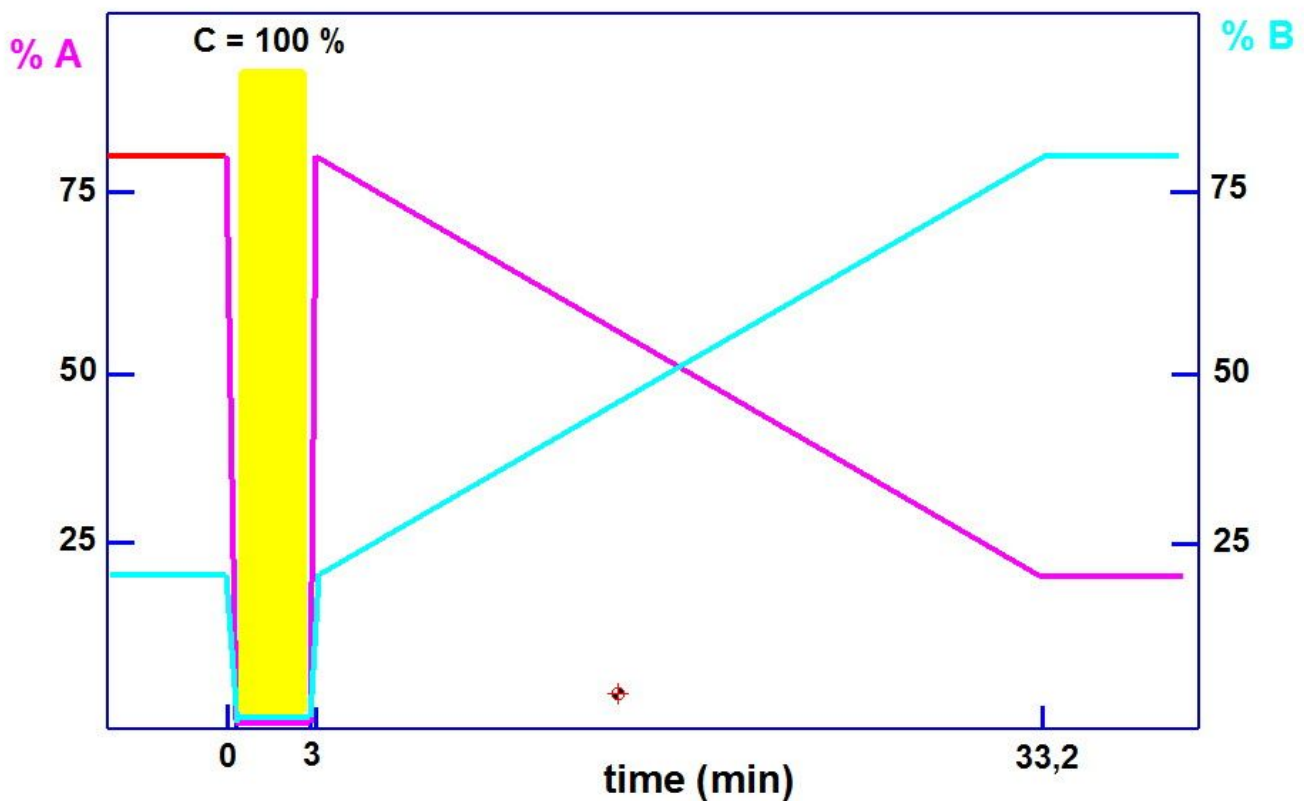

Fig. 13

Settings of values - notes

Use the F1 and F2 on the left keyboard next values can be set using the "arrow up" or "arrow down" buttons. If the arrow button is held down longer time (about 0.8) values begin to grow more and more fast. Then confirm set values by pressing ENTER is the moment when old values are rewritten into the device and executed. In the upper right corner of the display for about 1s displays ENTER in such case. If not, it is probably blocked due external control of transcription.

If for some reason do not want to write the changed value to the device, simply press F1 and then F2 to get the item to another screen and back again and loads the initial value is set. External control is described in ECOMAC software manual. It is possible to set and read everything as in the internal control, in addition it is possible to block the keyboard controls.

Calibration of the pump

Performed after entering the service password on the left keyboard. Attention: in these settings change the items set important parameters pumps! The first item is the "Settings Corection flow" which can be used for validation of the instrumetrn when fine correction of flow rate is necessary between of + -10%.

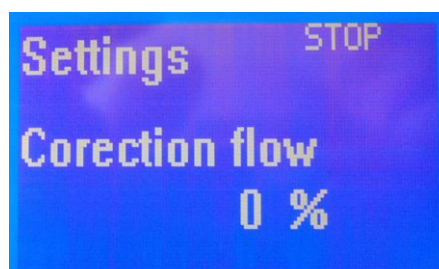

The next three items relate to the calibration gauge. The first is the "Settings Zero pressure". To execute it, the pump has to be in pressureless state. When figures on the display stabilize, press

ENTER. The transducer value for pressure 0 bar is recorded. Numerical data are raw, unadjusted data A / D converter, thus they are constantly changing a bit. The second is "Max pressure Settings" Here enter the value of the pressure at which is to calibrate the gauge. It is recommended to use at



least half of the maximum pump pressure. The third allows to set "Max pressure". Here pressurized to a pressure pump from the previous item and after stabilization figure press ENTER. A value of converter for a given pressure is recorded. Once calibrated repeatedly press the F2 key to leave the screen of calibration.

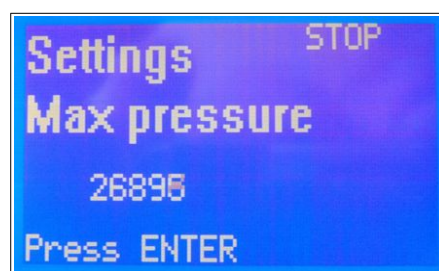

5. Additional installations

Pump PP 03 SAG can be used in different systems. Standard arrangement is given on first schema (Fig. 14):

Fig. 14

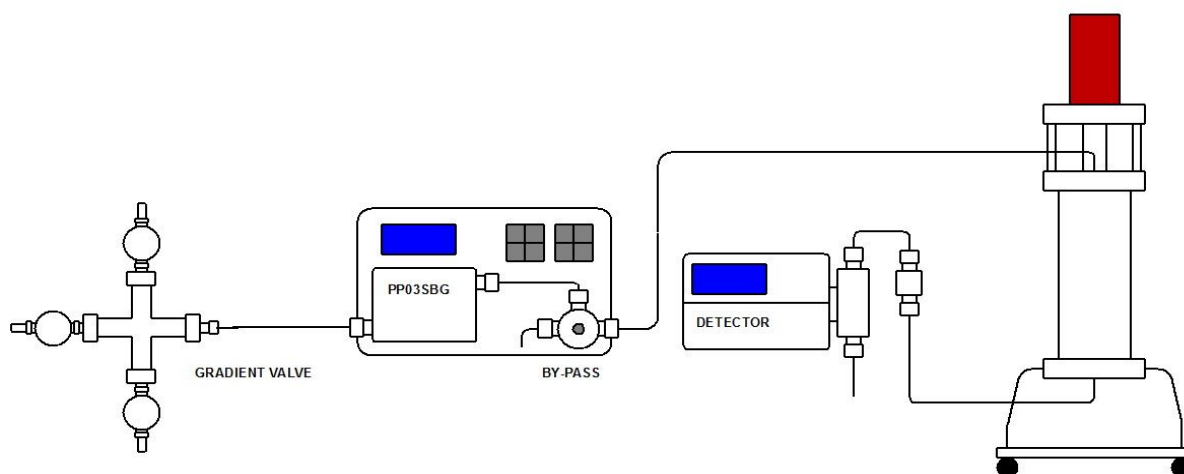

Nevertheless the pump can be used in other connections, as shown on the picture Fig. 15, where given a is recirculation schema.

For such application a pump can be equipped by two holders on both sides of the front panel where either recyclation, reversion or injecting valves can be situated (not a part of standard delivery) and is shown on Fig. 16:

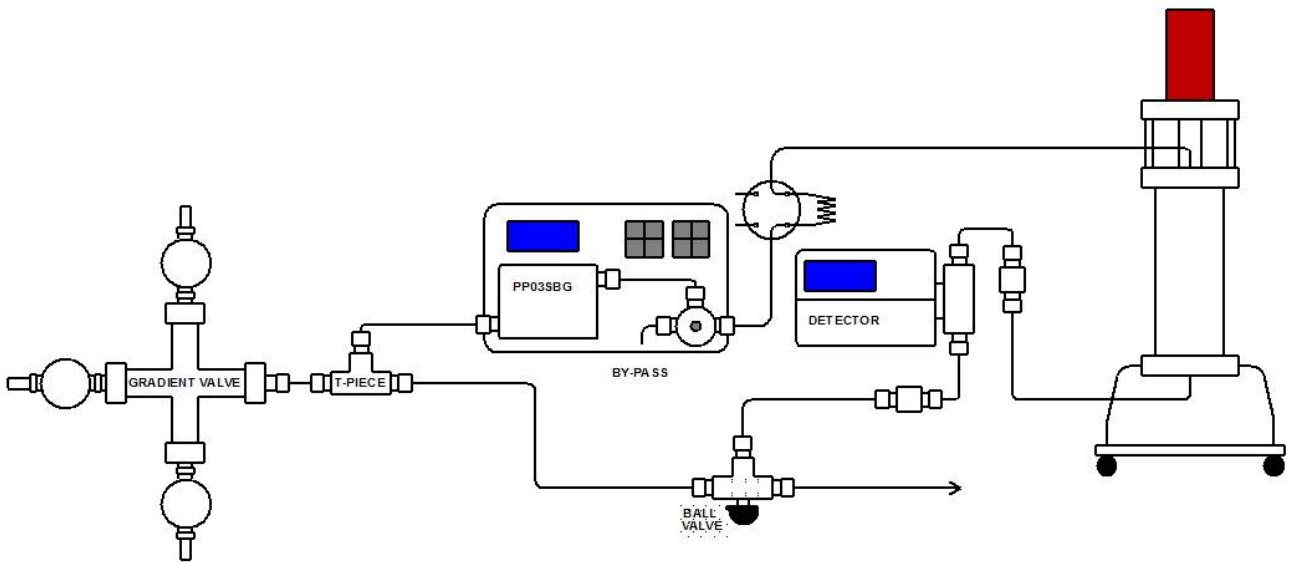

Fig. 15

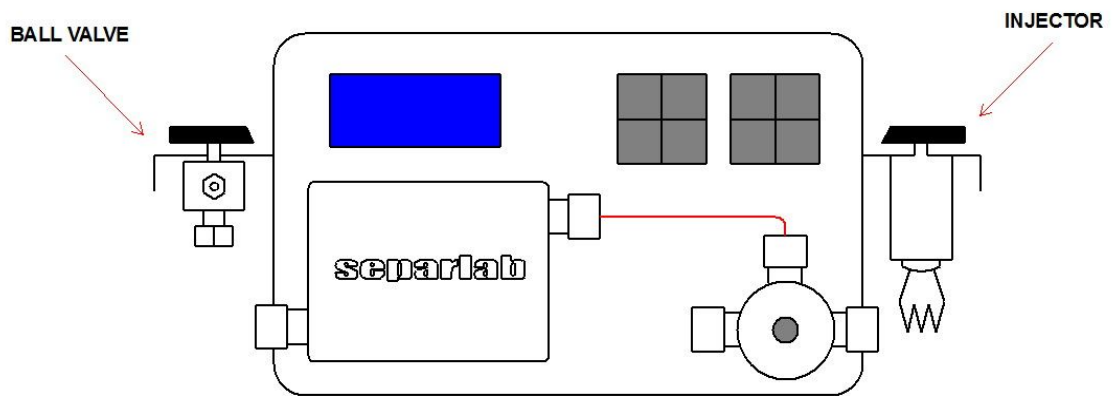

Fig. 16

Manufacturer:

Separlab Ltd.
 Rádiová 1122, 102 00 Praha 10, Czech Republic, Europe
 tel. + 420 736245343
 mail info@separlab.eu
 www www.separlab.eu

Annex 1

List of spare parts for pumps PP03

Type	Specifikacation	Unit	Price EUR/ unit
PP03 RP01	Input fitting PP 03 A,B,C head - Swalegok SS-600-1-6 for PP03 C, SS-400-1-6 for PP03 A,B	pc	
PP03 RP02	Output fitting PP 03 A,B,C head - Swalegok SS-600-1-6 for PP03C, SS-400-1-6 for PP03 A,B	pc	
PP03 RP03	Pump head PP03 A,B,C	pc	
PP03 RP04	Piston-PP03 A,B,C	pc	
PP03 RP05	Piston seal spring PP03 A,B,C	pc	
PP03 RP06	Forward spring insert PP03 A,B,C	pc	
PP03 RP07	Bacward spring insert PP03 A,B,C	pc	
PP03 RP08	High pressure sealing set PP03 A,B,C	set	
PP03 RP09	Low pressure sealing ring (backflash) PP03 A,B,C	pc	
PP03 RP10	Pressing screw hole PP03 A,B,C	pc	
PP03 RP11	Head cap	pc	
PP03 RP12	Head cap sealing	pc	
PP03 RP13	Input (suction) check valve cartridge PP03 A,B,C	cartridge	
PP03 RP14	Output (discharge) valve cartridge PP03 A,B,C	cartridge	
PP03 RP15	Connecting tube head- bypass valve PP03 A,B	pc	
PP03 RP16	Connecting tube head- bypass valve PP03 C	pc	
PP03 RP17	Bypass valve body	pc	
PP03 RP18	Screw hole bypass valve	pc	
PP03 RP19	By-pass valve needle	pc	
PP03 RP20	Seal of bypass valve needle axis	pc	
PP03 RP21	High pressure seal of bypass valve	pc	
PP03 RP22	Fixing ring of bypass valve needle seal	pc	
PP03 RP23	Input fitting bypass vlave PP 03 A,B (Swagelok SS-400-1-6)	pc	
PP03 RP24	Input fitting bypass valve PP03C	pc	
PP03 RP25	Output fitting bypass valve PP 03 A,B,C (Swagelok SS-200(400,600)-1-6)	pc	
PP03 RP26	Bypass fitting bypass valve (Swagelok SS-200-1-4RS)	pc	

By items where is A,B or C printed in BOLD is necessary to add proper letter to item type code.

Annex 2

PP03 G - communication via serial line

Basic parameters of the pump:

Flow: 1 – 800 ml/min

Pressure Limit: 2 - 150 bar

Pressure Hysteresis: 1 - 15 Bars

Gradient: three-component, 10 steps. You enter A, B, and time. C calculates.

Time step gradient: 180 min.

Speed: MODE COM1 9600Bd: 9600, N, 8,1

Table of commands

1char	2,3 char	The importance of the message	Answer	Note
?	<CR>			Query the device	PUMP_P1<CR>	
P	00	<CR>		STOP command station	OK<CR>	
P	01	<CR>		START command station	OK<CR>	
P	02	<CR>		The state program	P02xy<CR>	X = 0 Pump Stop x = 1 pump RUN y = 0 the gradient is at the beginning y = 1 gradient goes y = 2 gradient standing at the end
P	03	<CR>		STOP command gradient	OK<CR>	See note below
P	04	<CR>		START command gradient	OK<CR>	
P	05	<CR>		OFF keyboard command	OK<CR>	Permission is granted to view and stop values. It is not possible to change anything.
P	06	<CR>		ON keyboard command;nothing	OK<CR>	
P	07	<CR>		OFF command mode service	OK<CR>	
P	08	<CR>		ON Command mode service	OK<CR>	
P	09	<CR>			OK<CR>	

Note the gradient run: if the gradient runs, so after sending a command to stop the gradient, this gradient stops exercised gradient. The second command STOP gradient returns to the initial gradient (gradient 0) and only from the initial gradient of the gradient can start again. For this reason it is good prior to initiating a gradient, send STOP command twice a gradient, or when running gradient stops and then returns to its default gradient. Any extra gradient stop has no effect on the pump.

If the gradient is naturally stopped because of the end of the gradient, so it could be only one gradient stop to return to the initial gradient.

Table of input values

1char	2,3 char	The importance of the message	Answer	Note
P	10	nnnn	<CR>	Enter SPEED DRAWING	OK<CR>	1...800 ml/min int- 1 ml/min
P	11	nnnn	<CR>	Entering PRESSURE LIMIT	OK<CR>	3...150 Bar int. 1 Baru
P	12	nnnn	<CR>	Entering PRESSURE HYSTERESIS	OK<CR>	1...15 Bar int. 1 Baru
P	13	xxyz znnnn	<CR>	Entering gradient A, B, and time	OK<CR>	See bellow

Legend for P13 command:

The gradient can be entered only if the gradient is at the beginning (step 0), sometimes the data is rejected and sent back messages: ERROR-PG <CR>

xx ... 00-0A serial number of the step gradient (decimal 0-10)

yy ... 00-64 percent component A gradient (decimal 0 to 100)

zz ... 00-64 percent of component B gradient (decimal 0 to 100)

nnnn ... 0000-0708čas step gradient in tenths of minutes (dekadicky0 - 1800)

Note 1: The numbers are in hexadecimal

Note 2: In step 10, the time without meaning but must be entered, such as 0000

Note 3: The gradient tests: $A + B > 100\%$, and $A > 100\%$ and $B > 100\%$, if one condition is met is set to $A = 100\%$ and $B = 0\%$, or is set and the specified percent if $A < B$, 100% and the remainder to 100% .

note. 4: gradient runs in 6-second loop, where 1% is 0.06 s.

Table readout

1char	2,3 char	The importance of the message	Answer	Note
P	20	<CR>		Ask a specified rate at which	P20nnnn<CR>	
P	21	<CR>		Query to the specified pressure limits	P21nnnn<CR>	
P	22	<CR>		Query given PRESSURE HYSTERESIS	P22nnnn<CR>	
P	23xx	<CR>		Ask a gradient of A, B, and time	P23xxyyzznnnn<CR>	see up
P	30	<CR>		Ask the current SPEED	P30nnnn<CR>	
P	31	<CR>		Ask the current PRESSURE	P31nnnn<CR>	
P	33	<CR>		Ask the current gradient and B	P33xxyyzz<CR>	see up
P	34	<CR>		Query current time gradient	P34nnnn<CR>	

Table service mode

1char	2,3 char	The importance of the message	Answer	Note
P	80		<CR>	Calibration of gauge zero	OK<CR>	At zero pressure
P	81	nnnn	<CR>	Entering the calibration of pressure	OK<CR>	It is reasonable to use the 80% range of the gauge
P	82		<CR>	Calibration at the specified pressure	OK<CR>	When the calibration of pressure
P	83	nnnn	<CR>	Entering the correct pumping speed	OK<CR>	see bellow
P	90		<CR>	Ask to zero calibration gauge	P90nnnn<CR>	
P	91		<CR>	Query to the specified pressure calibration	P91nnnn<CR>	

P	92		<CR>	Ask a calibration value at a given pressure	P92nnnn<CR>	
P	93		<CR>	Ask a specified pumping speed correction	P93nnnn<CR>	

Service mode is accessible only after permission.

Correction is in the range -10% to +10%. entered after a full percentage of the 0 (0000 hex) corresponds to -10%, 10 (hexadecimal 000A) corresponds to 0% and 20 (0014 hex) corresponds to +10%

nnnn A hexadecimal number in the range 0 ... FFFFh expressed in ASCII characters (decimal range = 0 ... 65535)

xx A hexadecimal number in the range 0 ... FFh expressed in ASCII characters (decimal range = 0 ... 255)

... yy. A hexadecimal number in the range 0 ... FFh expressed in ASCII characters (decimal range = 0 ... 255)

zz A hexadecimal number in the range 0 ... FFh expressed in ASCII characters (decimal range = 0 ... 255)

Example: Decimal number 15 = 000Fh = hex ASCII characters: 0,0,0, F = ASCII code: 30h, 30h, 30h, 46h.

The time is in tenths of minutes. Example: 000Fh = 1.5 min

Pressure is in bar Example: 000Fh = 15 bar

Flow rate is 1 ml / min Ex: 000Fh = 15 ml / min

If the command is received and evaluated as unknown or erroneous message is sent back: ERROR <CR>

At runtime, you can not overwrite any data!! With this pump it is just entering the gradient in a running gradient (pump can run). Back ERROR message is sent, PG <CR>

The program evaluates both large and small letters as well

Example: command P5000F <CR> is identical with or p5000f <CR> P5000f <CR>

The program sends all letters as large (small alphabet is not used!)

Example: in response to p50 is <CR> P5000F <CR>

The device is used to buffer 10 characters (this should be extended to 256 characters). The actual evaluation is performed only after the final character "<CR>" if taken more than 10 characters, so characters are transcribed from the start buffer. For this reason, it is good to wait about 25 ms for processing messages on the device and then send a new message.

After receipt of any value that is checked in the range of allowed values and possibly modified to this extent.